

Eddy Current Array for Rivet Hole Inspection

Pairing Speed, Efficiency and Reliability

Alain HADDAD, Jr. Eng.
aelhaddad@eddyfi.com

AGENDA

- Rivet hole inspection
- Our solution
- Performances
- Solution advantages

Rivet hole inspection

RIVET HOLE INSPECTION

Context

- Rivet assemblies represents the main fixation system for aeronautic and aerospace structures.
- Lifetime affected by stresses leads to small cracking initiated in the rivet holes



Objective

Provide a new inspection solution using eddy current array techniques while pairing speed, efficiency and reliability

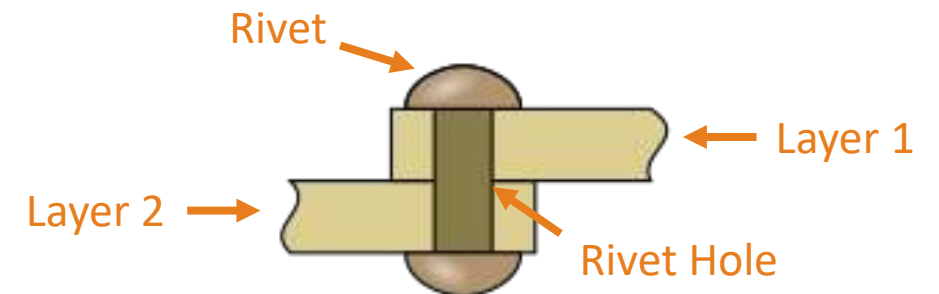

Rivet structural assembly

INSPECTION REQUIREMENTS

Client requirements

- Multi-layer of aluminium plates with a hole length range from 0.12 to 0.7 inches
- 0.5 inches hole ID with 100 mils variation
- Detection of axial cracks with the smallest crack having 80 mils Height x 20 mils Depth

Challenges

- Rivet hole geometry and restricted access
- Flaws located mainly on the layer transition

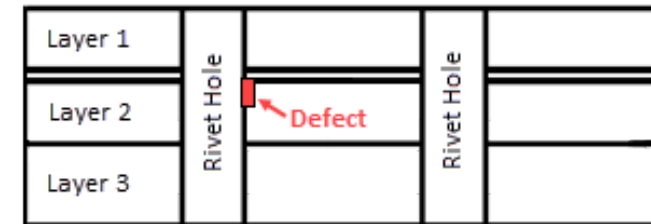

A-A section

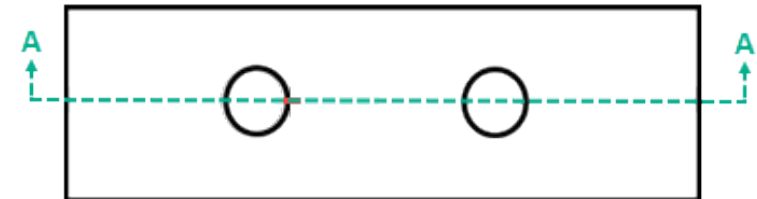

Top view

Defect representation in a triple layer sample

Our complete solution

OUR SOLUTION

A complete acquisition chain (probe, instrument and software), that is rapid and simple to deploy and answers the industry's need

Probe : Rivet hole ECA probe



EC instrument : Reddy



Acquisition and analysis software: Magnifi

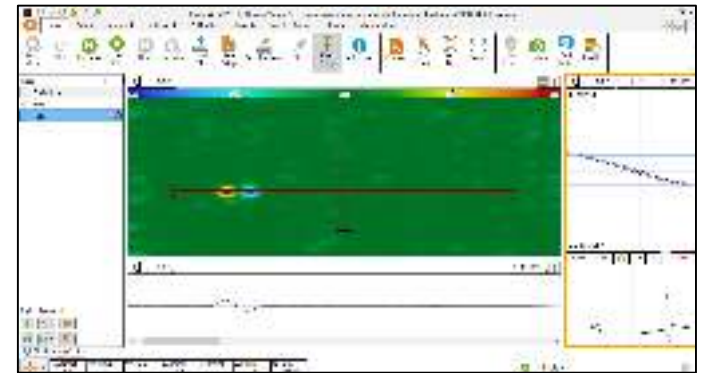

CUSTOM ECA PROBE

Configuration – Differential mode

- Coils are physically placed side-by-side
- Coils are excited and sensed at the same time
- One coil connected to positive input and the other to negative input

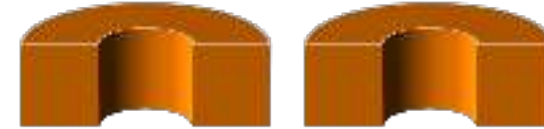

Physical configuration – side-by-side

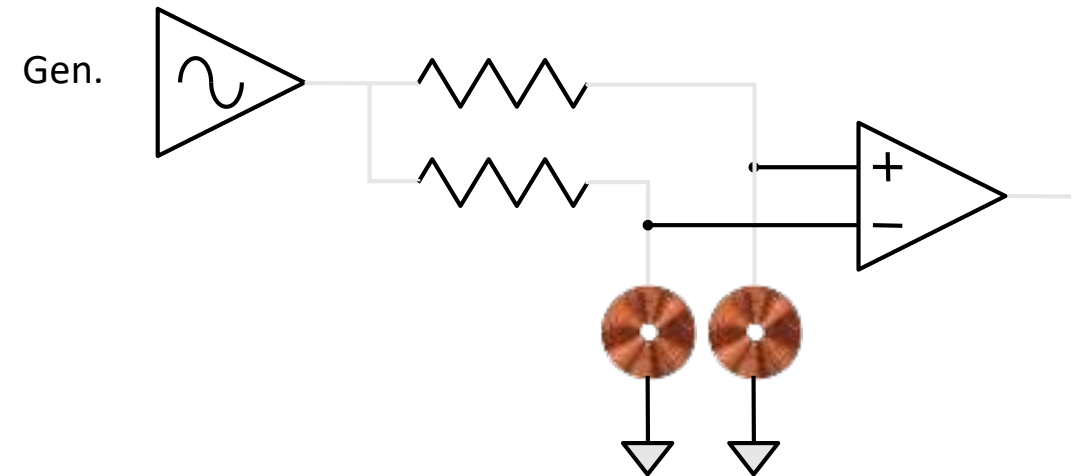

Operating mode

CUSTOM ECA PROBE

Signal response and advantages

- Signal from the subtraction of two sensors
- Double loop for each defect detected (8 shape)
- Very sensitive to short defects and provides a high signal-to-noise ratio
- Unaffected by gradual variations similar to lift-off, layer transition

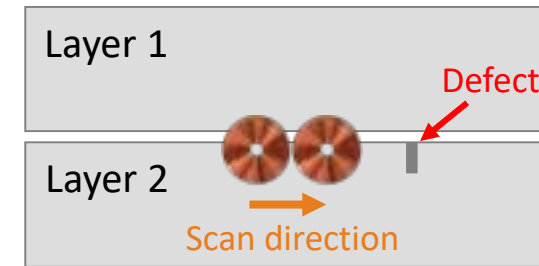

Inspection method – Defect located between layers

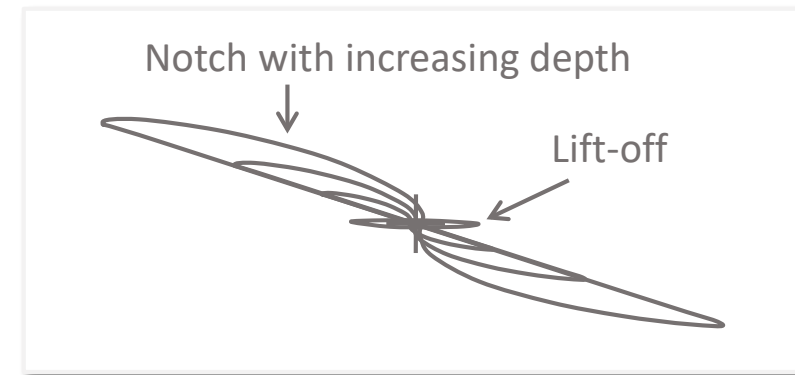

Differential mode – Signal response

CUSTOM ECA PROBE

Mechanical solution

- Adapted spring-loaded shoe
- 360-degree probe rotation
- Custom holder for a stable scan
- Encoded scans
- Easy-to-repair probe head
- Optional ceramic shoe for better durability

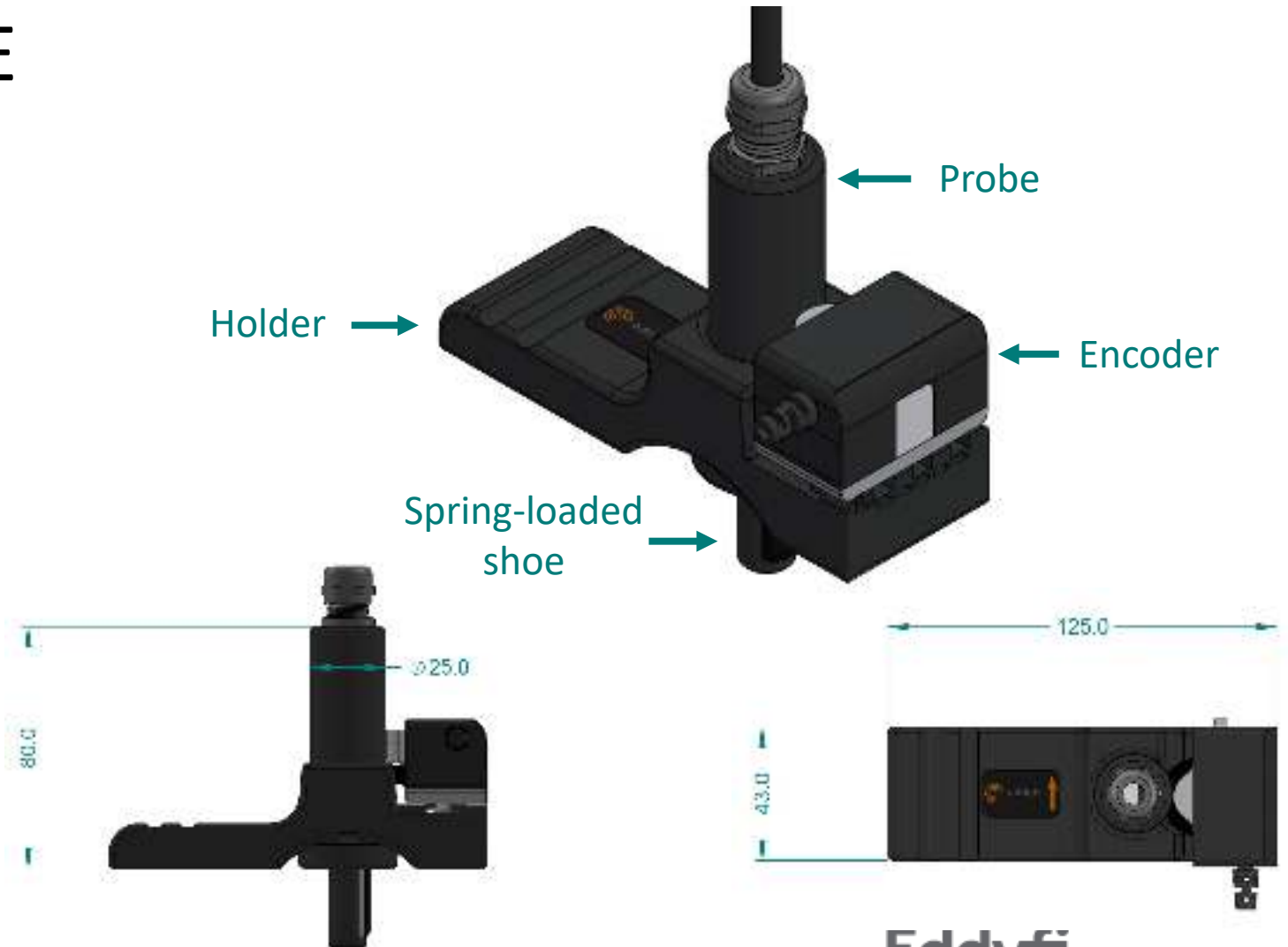

CUSTOM ECA PROBE

Coil arrangement

- Total of 46 coils generating 23 channels as for client's request
- Probe total coverage of 0.8 inches that can be increased if required
- Coil OD 60 mils centred at 1MHz with frequency range from 500 - 1500KHz

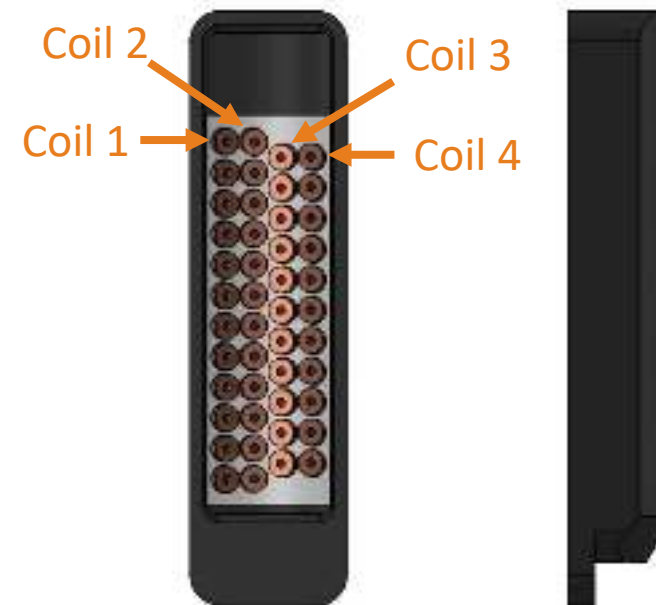

Spring-loaded shoe

EC INSTRUMENT

Reddy[®]



Proposed solution is compatible with the Reddy instrument

ACQUISITION AND ANALYSIS SOFTWARE

Magnifi overview

- Intuitive user interface
- Assisted analysis
- Automatic reporting
- Full data traceability

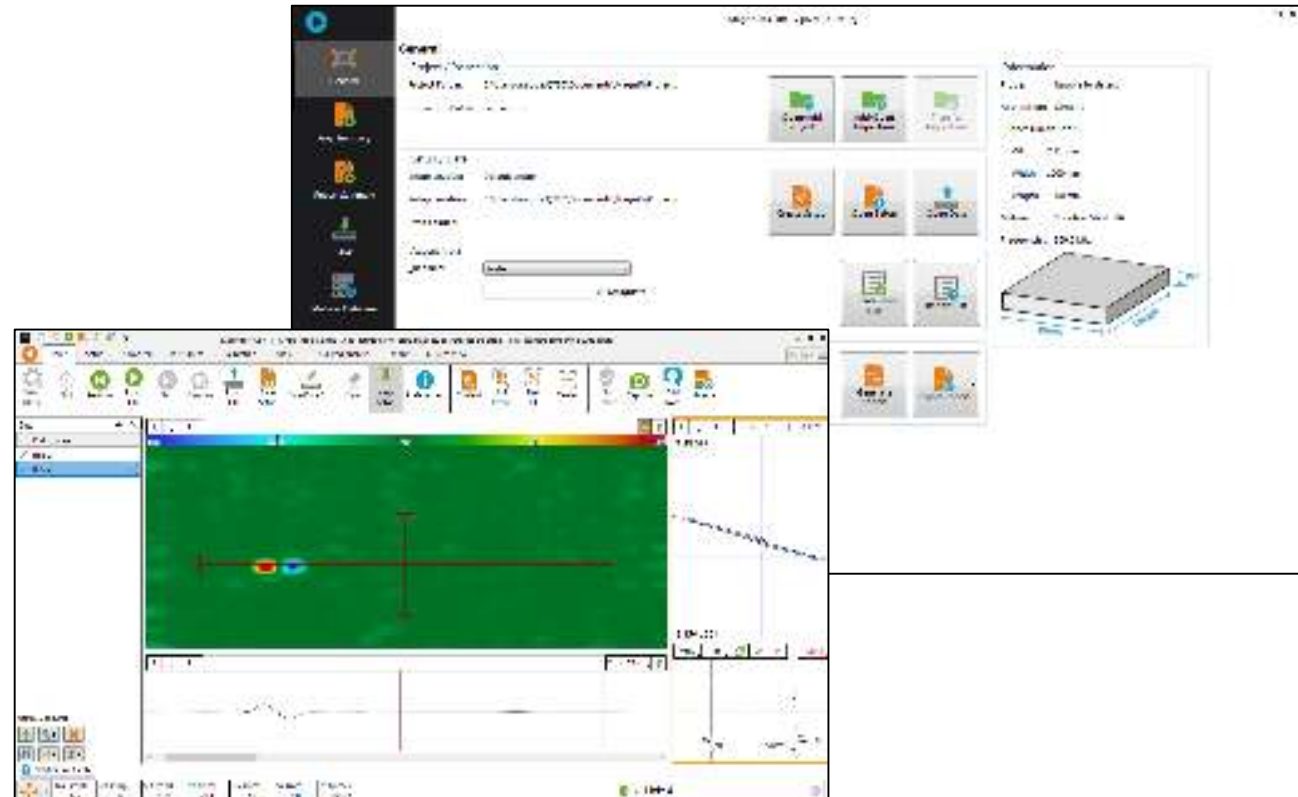

Performances

TEST SAMPLE

Sample composed by 3 layers having 8 rivet holes



TEST SAMPLE

Defect size
80 mils H x 40 mils D



Defect size
80 mils H x 40 mils D



Defect size
80 mils H x 20 mils D



QUICK DEMO

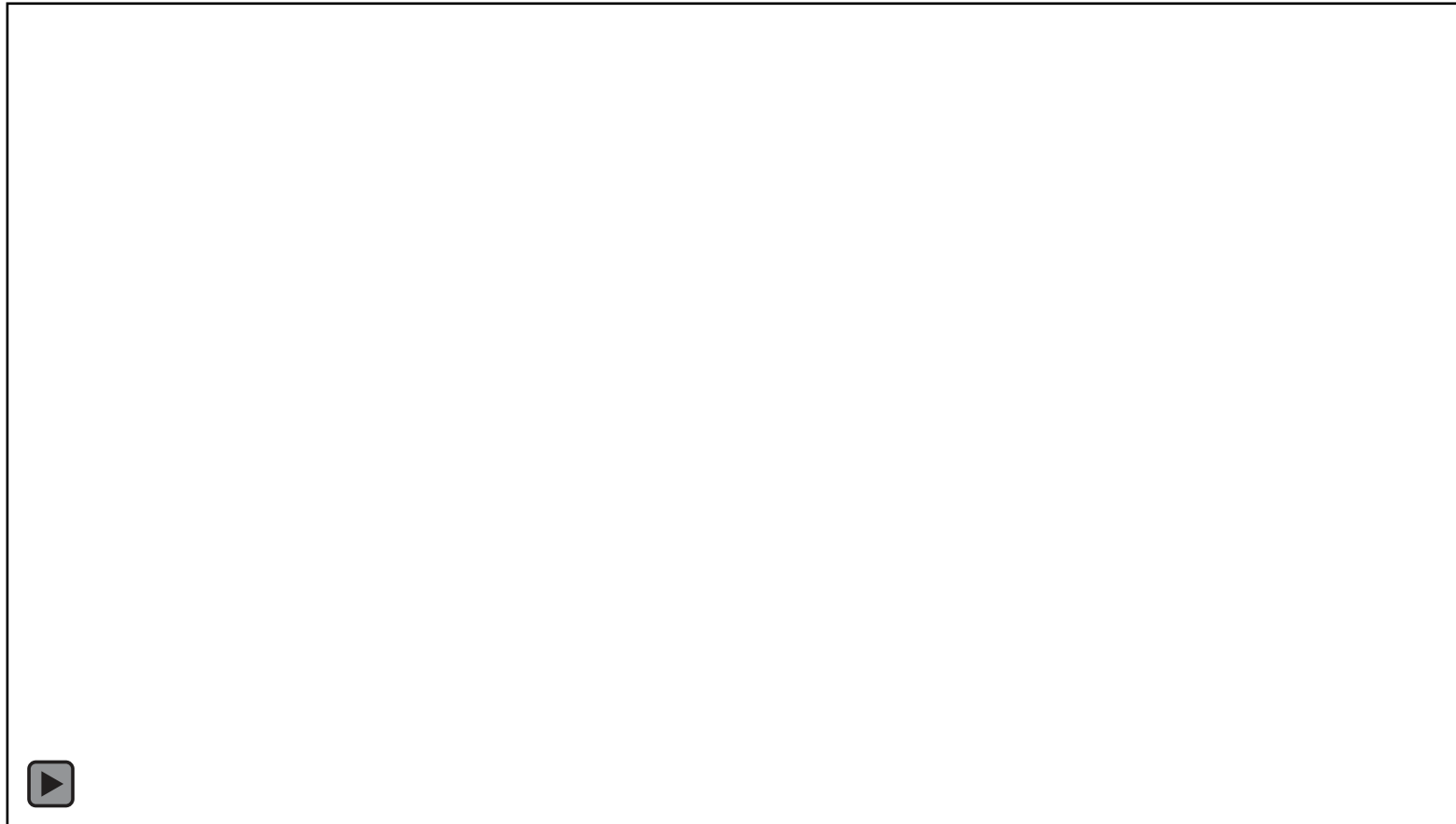

RESULTING DATA IN MAGNIFI

One defect identified in rivet hole #2

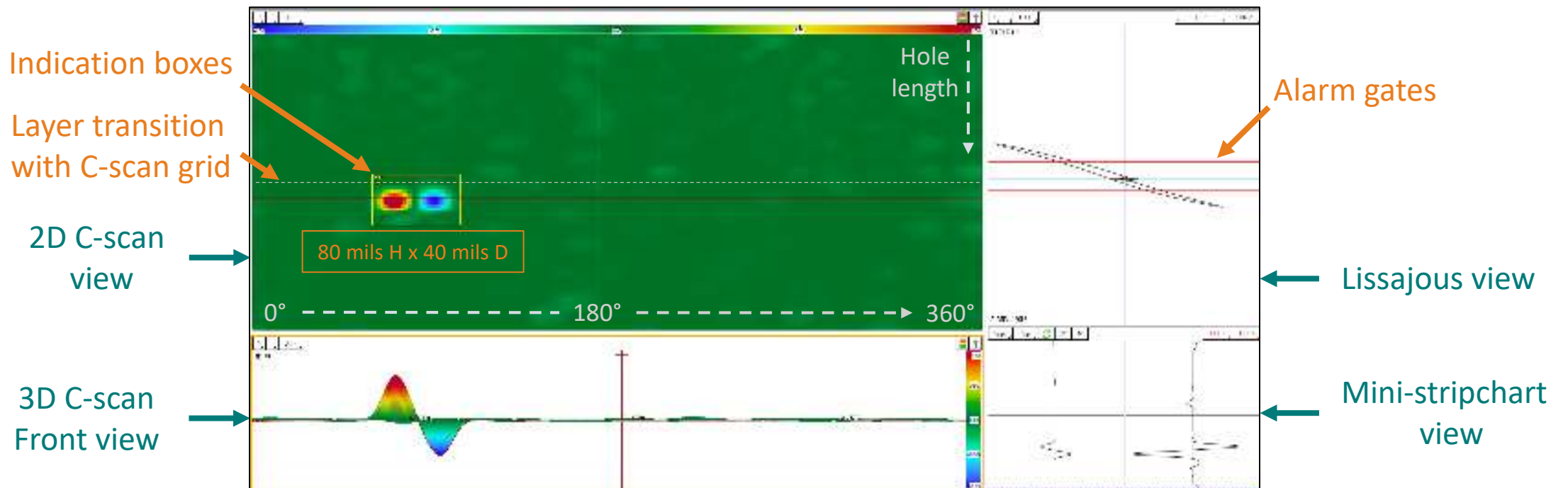

RESULTING DATA IN MAGNIFI

Two defects identified in rivet hole #4

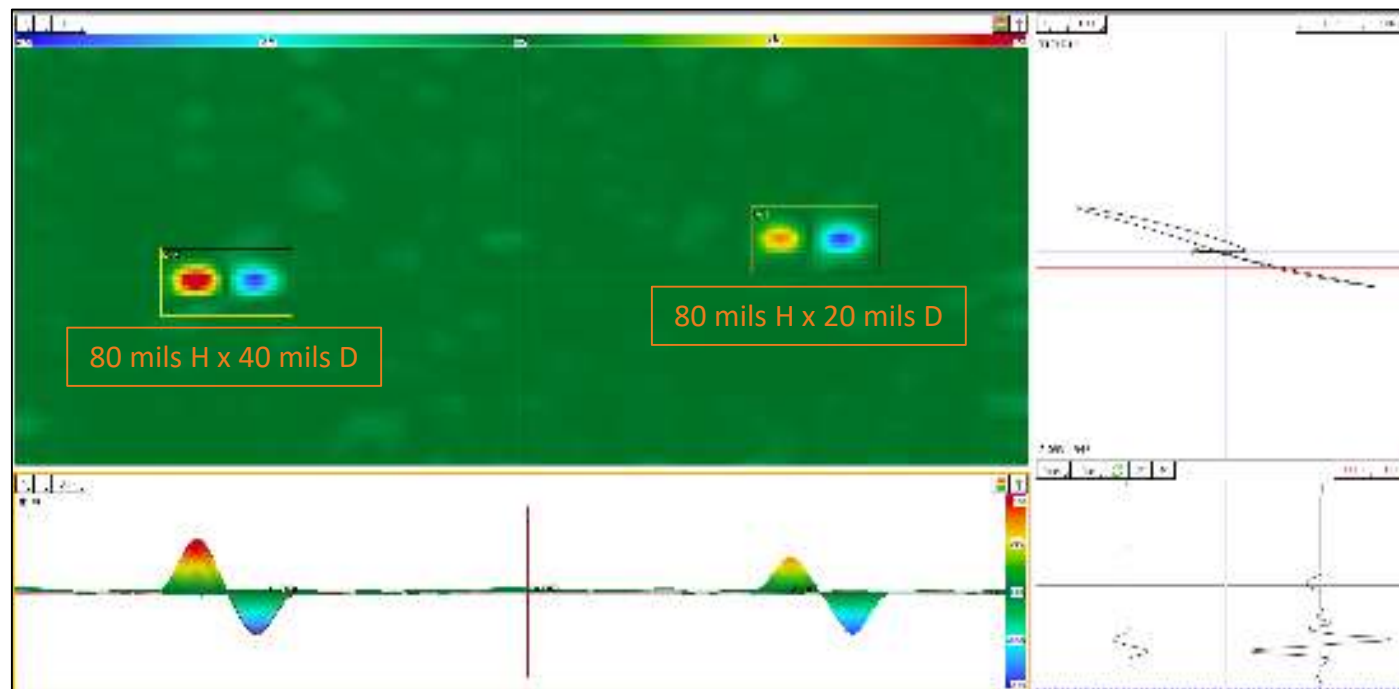

Solution advantages

FAST INSPECTION & AUTOMATIC REPORTING

Scan performed

Analysis

Automatic reporting

Rivet Hole inspection

Dedicated ECA probe

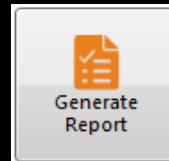
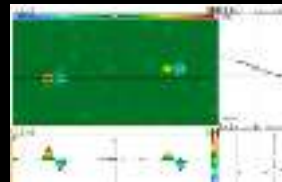

High speed – Single pass

Auto defect detection with alarm gates

One click report generation

Typical inspection workflow

Analysis Report 

Defect Table

N°	Process	Channel / Code	Code	Size	Area (mm²)	Angle (°)	Depth (mm)	Volume (mm³)
1	Roll 4	DRH	Crack Sharp		1.00	30°	0.03	0.04
2	Roll 4	DRH	Crack Sharp		1.00	30°	0.03	0.04

Analysis Report 

Defect Table

Generate Report

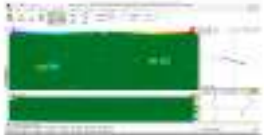
POWERFUL SOLUTION

- Human controlled factor
- Dynamic acquisition with integrated encoder for defect localization inside the hole
- Single-pass covering the full length of holes
- Unaffected by layer transition and very sensitive to small cracks initiating from this transition
- Very high signal-to-noise ratio (SNR)
- Can be adapted to a wide range of hole OD

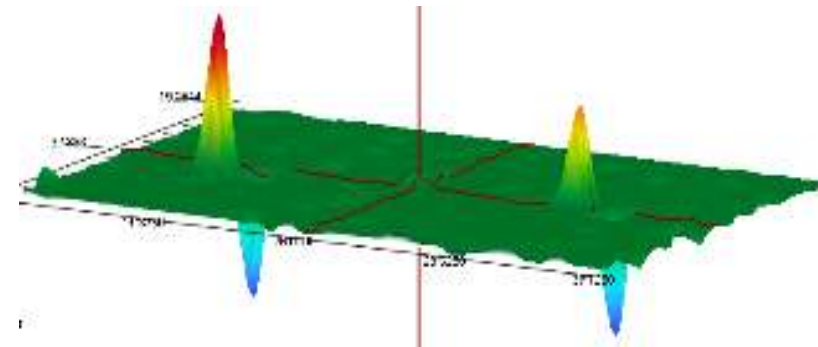
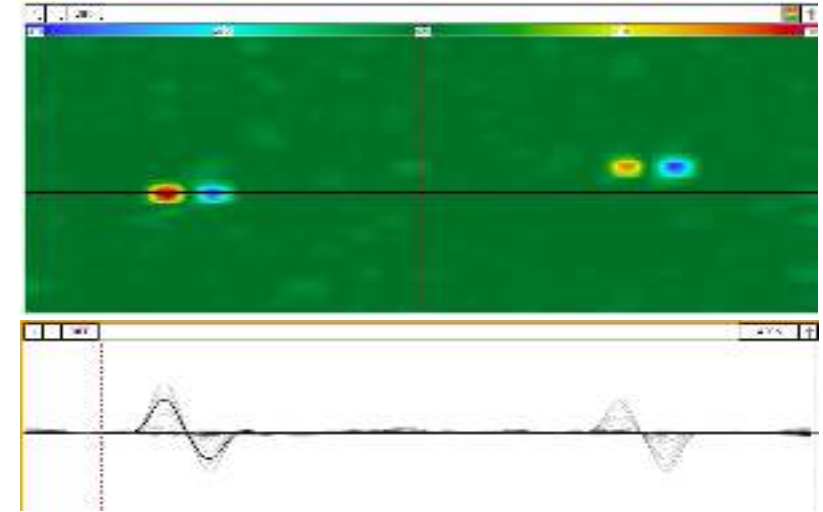

Thank you

