

CFM56 TRF Eddy Current

Sam Tucker
NDT Process Engineering
SFOEP

Jason Meade
Quality Control
HOUQC

2015 A4A NDT Forum
Fort Lauderdale, FL

A STAR ALLIANCE MEMBER 

eco-skies[™]
COMMITMENT TO THE ENVIRONMENT

UNITED



Overview

UA operates over 750 engines affected by AD's 2009-03-09 and/or 2010-01-05. Worldwide, the CFM56-7 engine fleet is nearly 8,400.



Compliance Requirements



CFM SB's 72-0568 and 72-0579 provide the inspection details for the repetitive on-wing eddy current inspections. SB effectivity is dependent upon TRF part number. AD is applicable only to part numbers in SB 72-0579 .

Inspection Area

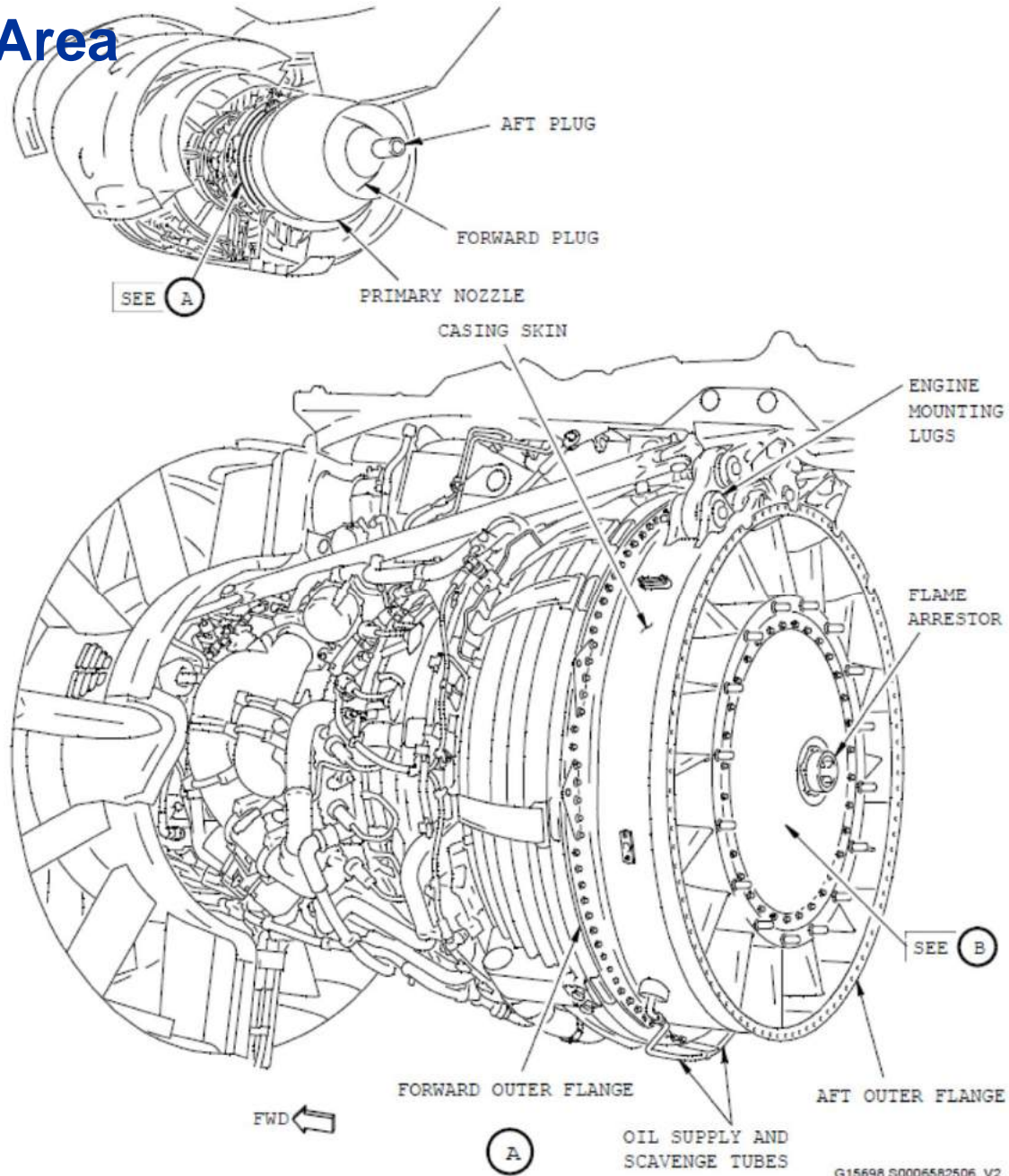

The procedure as written:

Choose the probe for the area
Set up on the reference standard



Identify the inspection areas



Identify the inspection areas- area C1

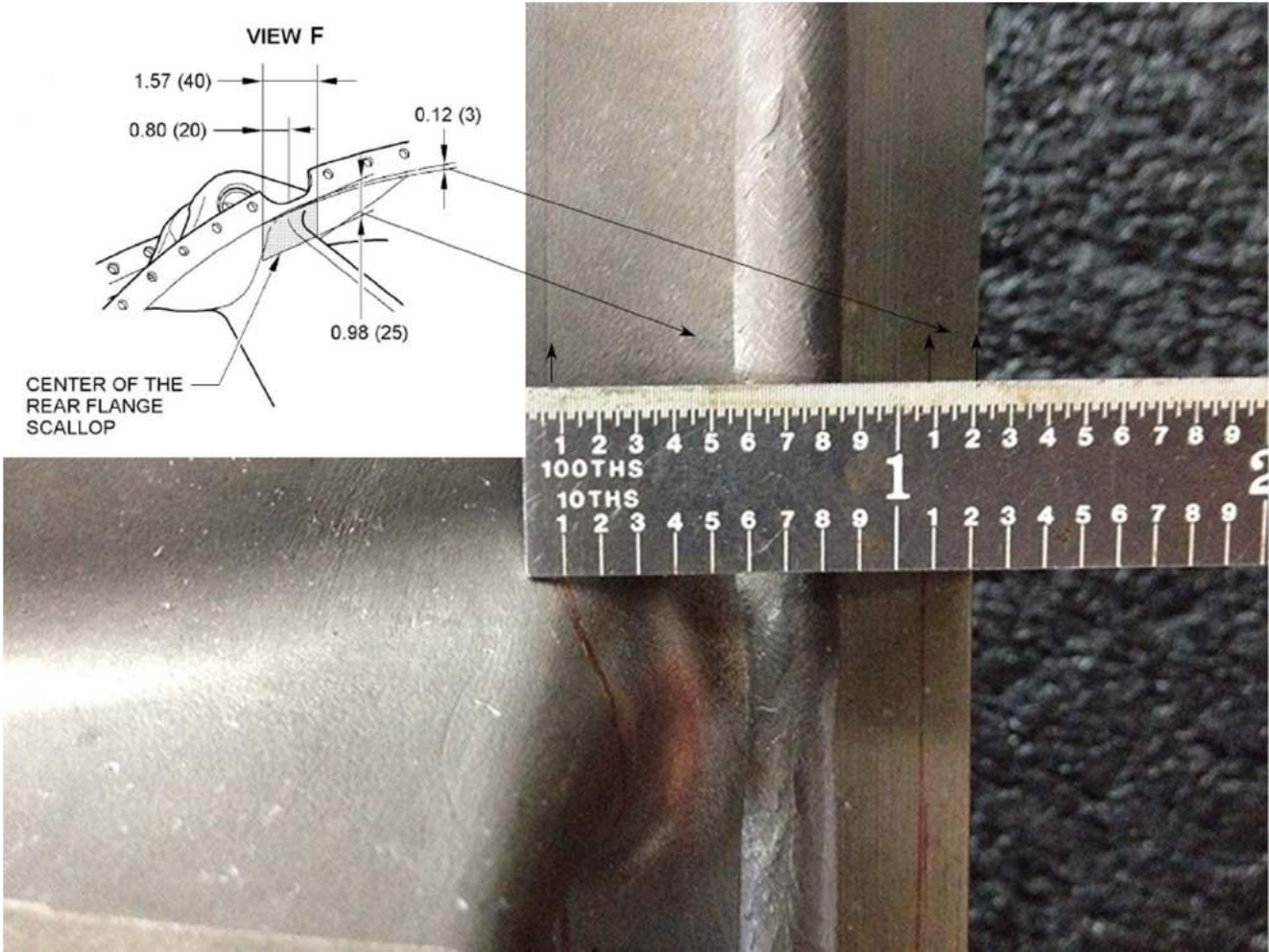

Identify the inspection areas- area C2

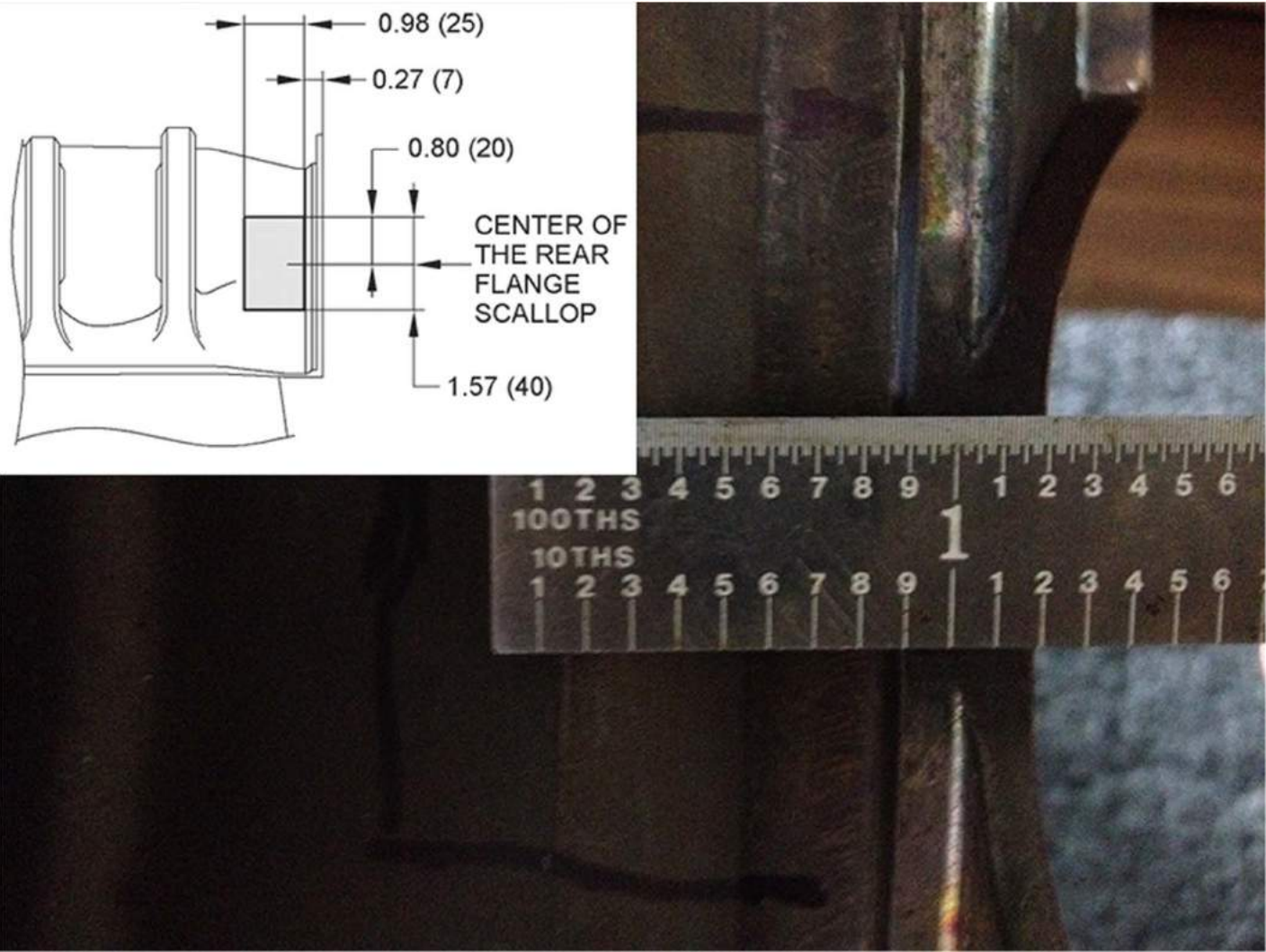

What does it look like when we scan across the weld?

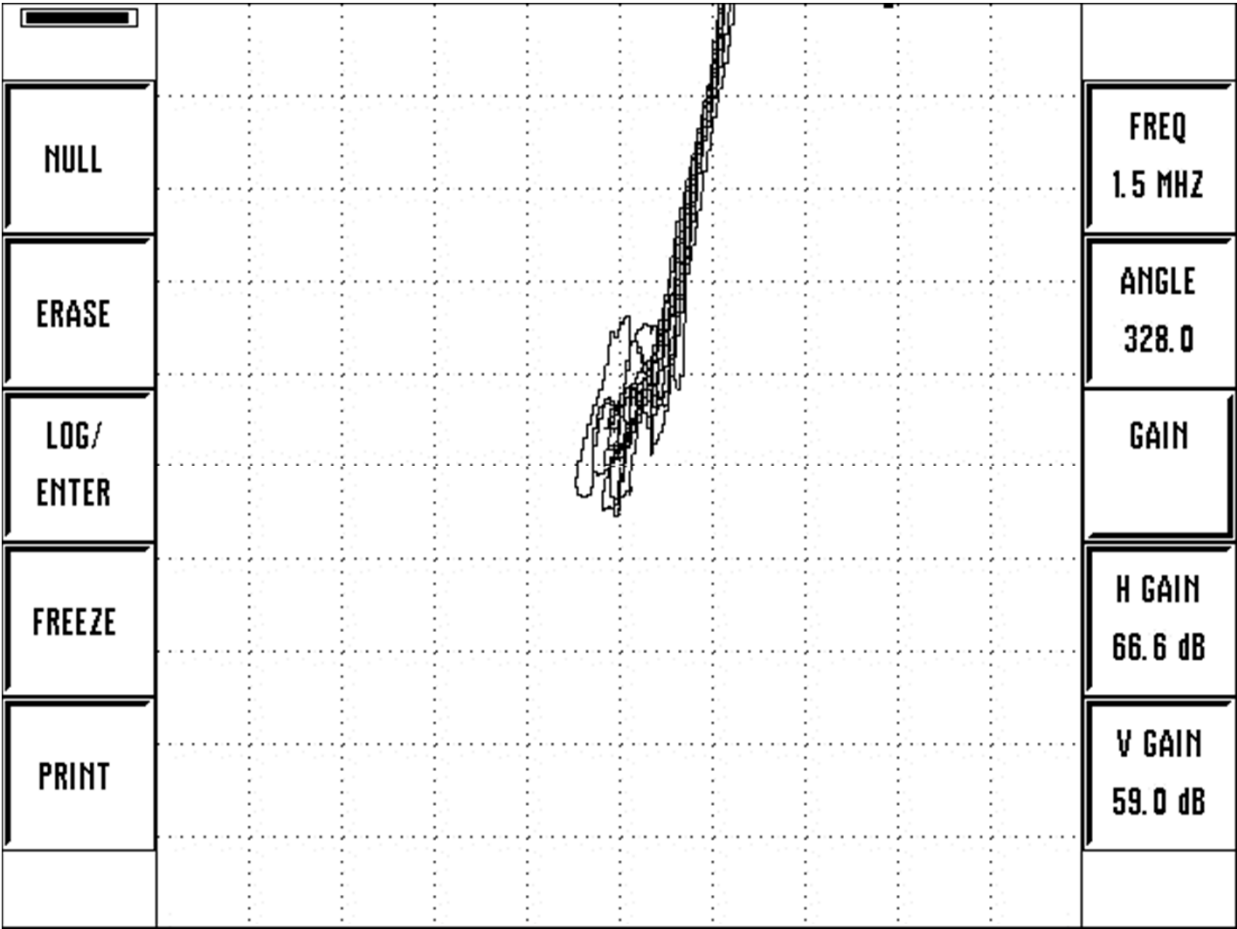

Rejectable signal = 1.5 divisions. Houston, we have a problem!

The next step

Contact Safran via GE rep asking for help

Initial response, use FPI;
this was later rescinded, with the
following email...

“November 05, 2014

Dear Customer,

CFM has no objection that UA develops a specific probe
for ECI inspection of weld beads...”

Stephane Furic, CFM PSE



Developing a probe

We had a good idea that the answer was most likely a dual coil probe for inspecting the weld. This still left a problem:

How do we try out what is available without spending a lot of money on R&D?



November 2014- SB 72-0568 due- we have an inspection to prototype on live aircraft and no solution yet...

- Contacted GE and Olympus- both were willing to help
- Borrowed “Weldscan” probe to attempt a solution



The Southwest Factor



One more thing to try...



The Eureka! Moment...

- Neither of the borrowed weld probes we tried would set up on the ref standard...
- The Uniwest US-1839 gave a nice signal on the reference standard. Instead of 10 degrees of separation, we had 180!

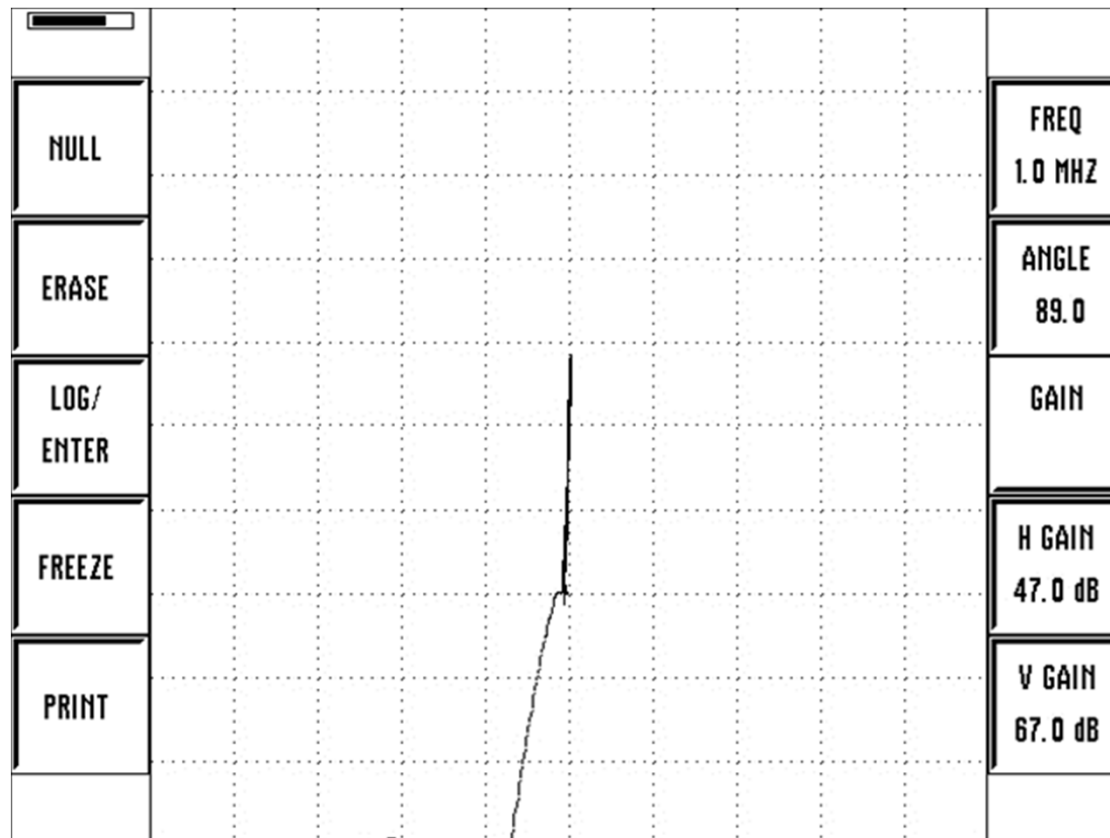

Will the US-1839 work on the scrap frame?

YES!

But what is this???

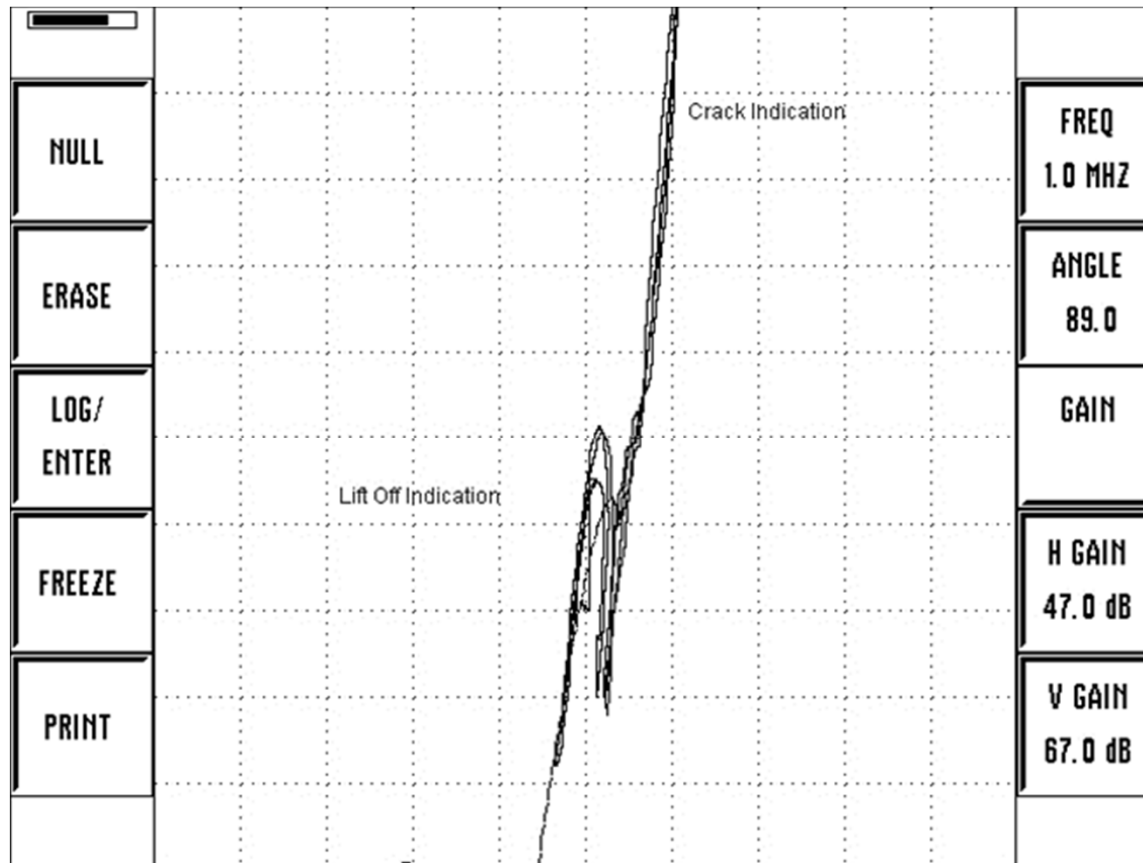

The scrap frame section is cracked in area C1!



Refining the solution- can we get a modified US-1839?



We need a shorter version- Uniwest comes through with US-3530

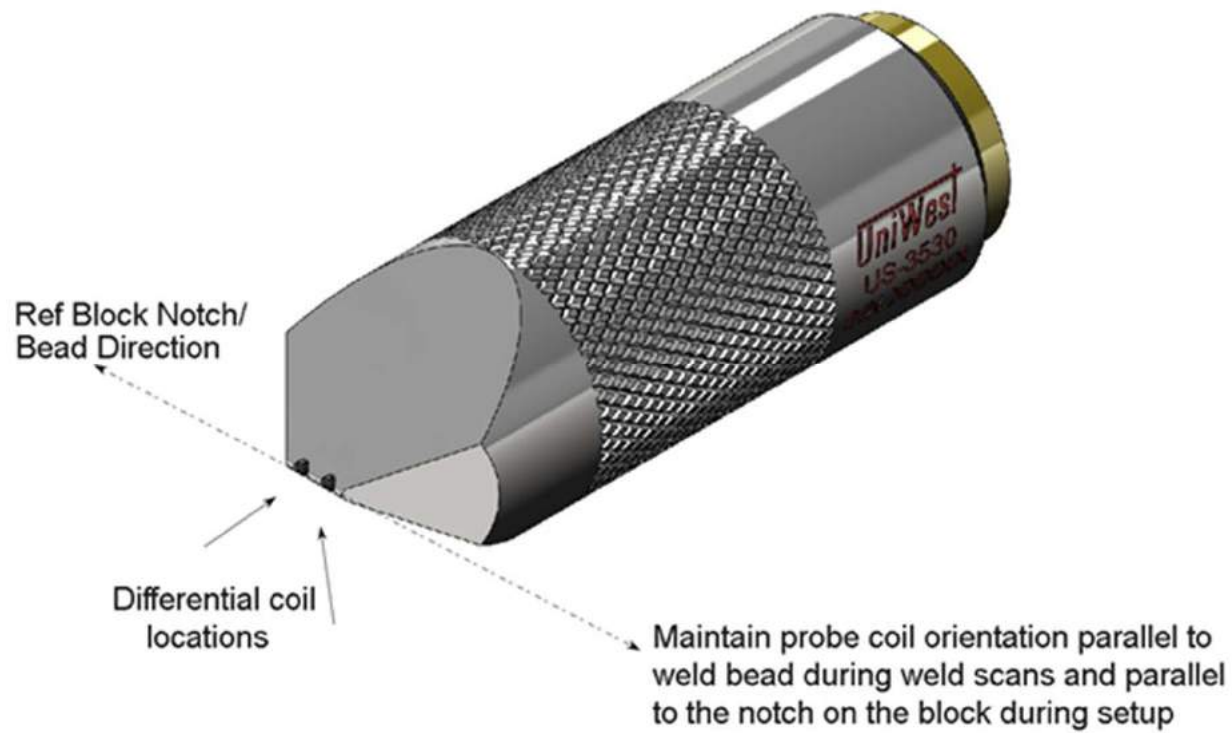

Next stop- Paris

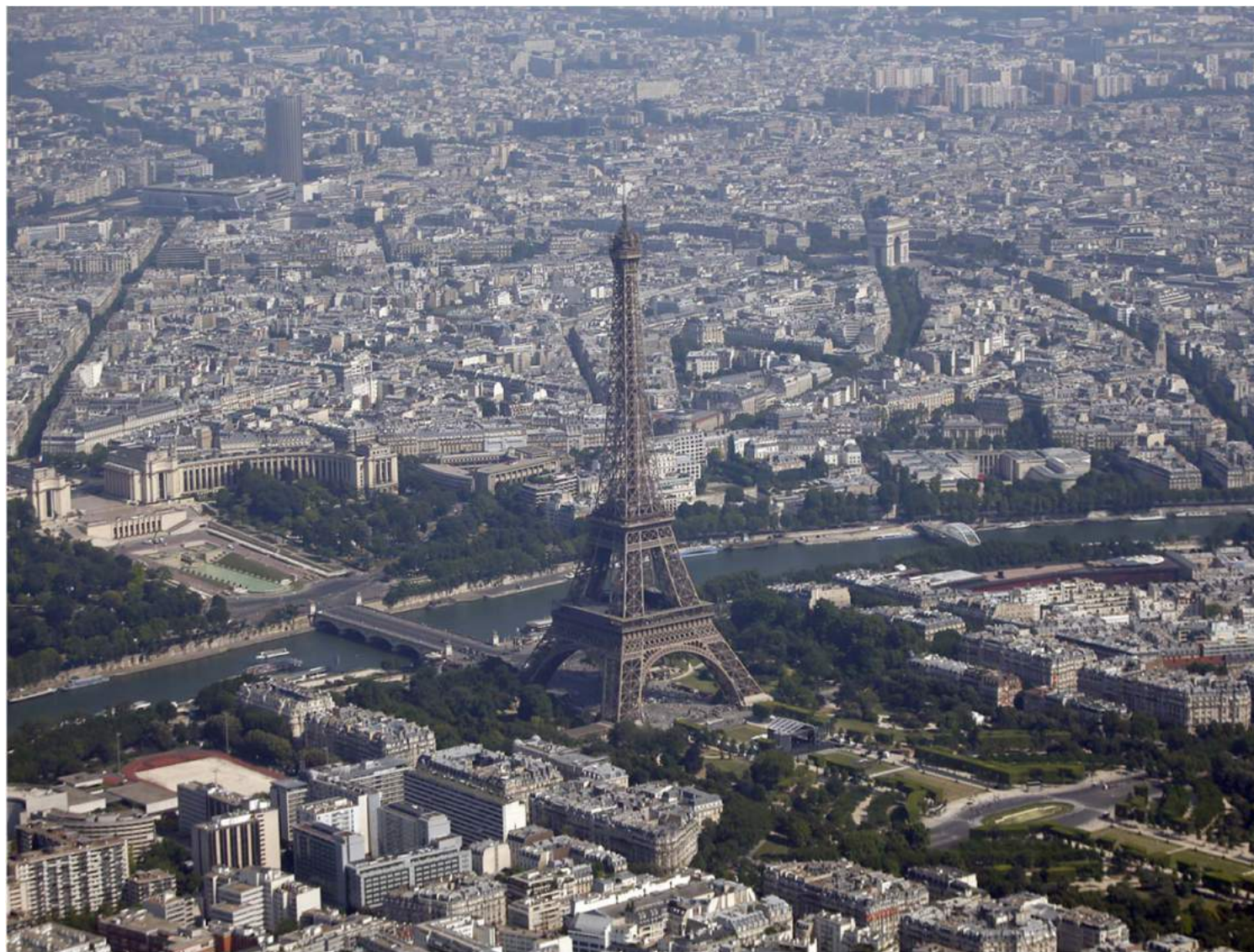

All done but....



Conclusion

- Once approved, this solution will save millions in engine changes while enhancing POD
- Safran has projected approval for 4Q 2015
- SB revision will hopefully provide global AMOC
- Collaboration made it happen- thanks to all!

Dorsey Perkins, Southwest Airlines

Nellie Mauzey, GE Strother

Bryan Leach, Uniwest

Jason Meade, United Airlines

Cyril Collot, Safran

Questions?

